



Lih Pneumatic

Pneumatic tools manufacturer and supplier in Taiwan





POWER PERFECT TAIWAN

Power Perfect Co. was established in 1986 by Mr. Zai-Rong Fang. With more than 30 years experiences, we have given our own pneumatic tool brand “Lih” a creditable reputation in the field. With its foundation in Taiwan, Lih has been going to global market.

The company had been transferred from mold and plastic injection areas, we completely understand the demand of user. High quality, Trust and Service are the crucial principles for us; therefore, we become increasingly responsive to the customer base.

Our people start the day, everyday, with the drive to develop, manufacture and deliver the products that meet our customers’ demand in the world.

We insist that great tools not only could improve working efficiency but also create more possibility for your business.

— ***Power Perfect***





Comprehensive Product Range

The products have been improved year by year for the painting, the structure, the materials, etc. We will always try to meet the demand of the market, and do our best to satisfy our customer base.



We believe the quality of Taiwan is a brand and a trust. Our “Made In Taiwan” is being supported by many precise machines, technicians and developer.



Made In Taiwan



Utility Patents and Design patents

We design and improve our products continuously and year by year. Owned many design and development patents and has registered the trademark in several countries.



For our customer worldwide, it is important to assure the efficiency of the delivery. We support air & sea freight. We ship goods on-time and give you a comprehensive freight service.



On-Time Delivery



Professional Pneumatic Grinders





PRODUCT FEATURES

Applying Highly-Precise Bearings

According to products' characteristic, we adopt several world-class bearing brands to ensure our products quality.



Du-Pont Engineering Blades

Our products' blades are made by Du-Pont Vespel material which can improve.

- Reducing abrasion
- High-temperature resistant
- Highly self-lubricating
- Extending product lifecycle



Twist Switch

Twist switch is suitable for continuous operation. Easy to adjust speed, easy maintenance and laborsaving.



Bronze Air Muffler

It can be used to reduce dynamic noise from the exhaust ports of air valves. It is also used as filter to prevent metal chips, abrasive grits, dust from outside.



Exhaust Silencer Hose

A unique design that provides effective noise suppression.

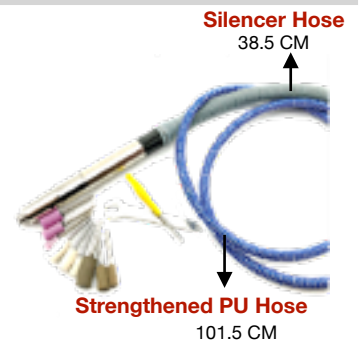

Mounted Points Included

Diverse mounted points are also available in our company. Abrasive is also included in some products' packing.



Complete & Clear Packing

A safe and simple packing is our insistence for protecting product and presenting a good image.





-RECIPROCATING-

Patent turbine motor and patent liner bearing. Highly durable and best-seller for many years. Particularly practical for polishing narrow areas and corners of components.



-SWING TRACK-

High torque grinding series. Precise design and assemble. Good at Polishing on strip object and Finishing at narrow pipe.



-ROTARY TRACK-

All series are applied aviation-class bearings to support high working speed. Applying any material, environment and angle. Impressive experience with 80,000 rpm power.



	Rotary Track	Reciprocating Track	Swing Track
Average Weight (g)	82~183	166~367	325~573
Average Speed (rpm)	60,000~80,000	10,000~55,000	28,000~35,800
Stabilisation	High	Average	Low
Model Diversity	25+	15+	4+

旋轉式氣動刻模機 Pneumatic Die Grinder

AIR-825



- The lightest tool in all product lines which only 82 g.
- No-load operation speed can be 65,000 rpm maximum.
- Chuck is changeable, chuck diameter 3, 1/8, 2.4 (mm)

轉速 Speed	夾頭 Chuck	尺寸 Dimensions	重量 Weight
65,000 rpm	∅ 3, 1/8, 2.4 mm	∅18×150 mm	82 g

AIR-828



- One of best-seller products in "Lih" brand
- Anti-slip line on tool case
- No-load operation speed can be 65,000 rpm maximum.
- Chuck is changeable, chuck diameter 3, 1/8, 2.4 (mm)

轉速 Speed	夾頭 Chuck	尺寸 Dimensions	重量 Weight
65,000 rpm	∅ 3, 1/8, 2.4 mm	∅18×150 mm	112 g

AG-3M1

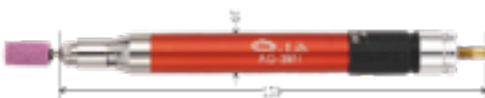

- Adopting Germany Bearings, More Durable, Longer Product-Life
- No-load operation speed can be 65,000 rpm maximum.
- Chuck is changeable, chuck diameter 3, 1/8, 2.4 (mm)

轉速 Speed	夾頭 Chuck	尺寸 Dimensions	重量 Weight
65,000 rpm	∅ 3, 1/8, 2.4 mm	∅16×150 mm	110 g

AG-3M2



- Adopting Germany Bearings, More Durable, Longer Product-Life
- No-load operation speed can be 65,000 rpm maximum.
- Chuck is changeable, chuck diameter 3, 1/8, 2.4 (mm)

轉速 Speed	夾頭 Chuck	尺寸 Dimensions	重量 Weight
65,000 rpm	∅ 3, 1/8, 2.4 mm	∅16×150 mm	110 g

AIR-4G



- Hyper operation speed that up to 80,000 rpm maximum
- Motor is assembled by 4-piece bearings
- Highly stable and good for handling

轉速 Speed	夾頭 Chuck	尺寸 Dimensions	重量 Weight
80,000 rpm	∅ 3 mm	∅17×159 mm	169 g

AIR-8G



- Hyper operation speed that up to 80,000 rpm maximum
- Motor is assembled by 4-piece bearings
- Chuck is changeable, chuck diameter 3, 1/8, 2.4 (mm)

轉速 Speed	夾頭 Chuck	尺寸 Dimensions	重量 Weight
80,000 rpm	∅ 3, 1/8, 2.4 mm	∅18×154 mm	168 g

GT-A260



- One of best-seller products in “Lih” brand
- No-load operation speed can be 60,000 rpm maximum.
- Chuck is changeable, chuck diameter 3, 1/8, 2.4 (mm)
- Highly stable and good for handling

轉速 Speed	夾頭 Chuck	尺寸 Dimensions	重量 Weight
60,000 rpm	∅ 3 mm	∅17×155 mm	169 g

AIR-3M



- One of best-seller products in “Lih” brand
- No-load operation speed can be 65,000 rpm maximum.
- Light weight, High torque, Also has a long product life
- Highly stable and good for handling

轉速 Speed	夾頭 Chuck	尺寸 Dimensions	重量 Weight
65,000 rpm	∅ 3 mm	∅17×145 mm	132 g

旋轉式氣動刻模機 Pneumatic Die Grinder

AIR-906



- One of high-torque tools in “Lih”
- No-load operation speed can be 35,000 rpm maximum.
- Rubber case which is suitable for cold weather
- Chuck diameter 3 & 6 mm

轉速 Speed	夾頭 Chuck	尺寸 Dimensions	重量 Weight
35,000 rpm	∅ 3, 6 mm	∅26×150 mm	230 g

GT-A380

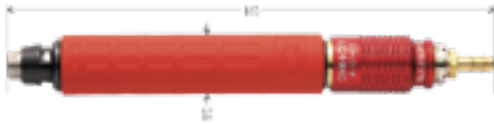

- One of best-seller products in “Lih” brand
- Hyper speed grinder which can be 80,000 maximum
- Rubber case which is suitable for cold weather
- Patent in the whole tool

轉速 Speed	夾頭 Chuck	尺寸 Dimensions	重量 Weight
80,000 rpm	∅ 3, 1/8, 2.4 mm	∅18×165 mm	183 g

FX-3.0



- Durable product, Beautiful Paint, Good for handling
- Operation speed can up to 65,000 maximum
- Improved tool, Better than ever, Easy for after-service

轉速 Speed	夾頭 Chuck	尺寸 Dimensions	重量 Weight
65,000 rpm	∅ 3 mm	∅20×155 mm	176 g

AIR-586A



- Operation speed can up to 65,000 maximum
- Improved model, Lighter, Thinner, and Better
- Japan Bearings and Blades, Quality Guarantee

轉速 Speed	夾頭 Chuck	尺寸 Dimensions	重量 Weight
65,000 rpm	∅ 3, 1/8, 2.4 mm	∅22×180 mm	120 g

AIR-591



- Very useful to any large-sized object or mold
- Changeable Chuck which fit to 3, 6 (mm)
- Containing 5 bearings to improve high torque
- Good for handling with delicate cover paint

轉速 Speed	夾頭 Chuck	尺寸 Dimensions	重量 Weight
28,000 rpm	∅ 3, 6 mm	∅34×280 mm	560 g

AIR-592



- Very useful to any large-sized object or mold
- Changeable Chuck which fit to 3, 6 (mm)
- Containing 5 bearings to improve high torque

轉速 Speed	夾頭 Chuck	尺寸 Dimensions	重量 Weight
28,000 rpm	∅ 3, 6 mm	∅34×250 mm	530 g

AIR-593



- Very useful to any small or precise object or mold
- Changeable Chuck which fit to 3, 6 (mm)
- Highly-stable and high torque
- Japanese bearings to maintain durability and efficient output

轉速 Speed	夾頭 Chuck	尺寸 Dimensions	重量 Weight
28,000 rpm	∅ 3, 6 mm	∅34×190 mm	369 g

AIR-810



- Operation speed can up to 65,000 maximum
- Changeable Chuck which fit to 3, 1/8, 2.4 (mm)
- Adopting Du-Pout engineering material to produce blades
- Good for handling with delicate cover paint

轉速 Speed	夾頭 Chuck	尺寸 Dimensions	重量 Weight
65,000 rpm	∅ 3, 1/8, 2.4 mm	∅29×158 mm	190 g

旋轉式氣動刻模機 Pneumatic Die Grinder

AIR-890



- 90° angle that can grind object completely
- Abrasive wheel can adopt $\varnothing 20, 30, 45$ (mm)
- Highly-Durable motor, the design is good for maintenance
- Good for handling with delicate cover paint

轉速 Speed

35,000 rpm

夾頭 Chuck

$\varnothing 30$ mm

尺寸 Dimensions

$\varnothing 29 \times 50 \times 158$ mm

重量 Weight

200 g

AIR-845



- The most popular working angle 45°
- Abrasive wheel can adopt $\varnothing 20, 30, 45$ (mm)
- Highly-Durable motor, the design is good for maintenance
- Good for handling with delicate cover paint

轉速 Speed

35,000 rpm

夾頭 Chuck

$\varnothing 30$ mm

尺寸 Dimensions

$\varnothing 29 \times 50 \times 168$ mm

重量 Weight

236 g

AR-280



- Heavy-duty die grinder, High Torque
- Maximum air pressure can sustain 150 psi
- Chuck diameters are 3 and 6 mm, support a wide range of abrasive

轉速 Speed

40,000 rpm

夾頭 Chuck

$\varnothing 3, 6$ mm

尺寸 Dimensions

$\varnothing 30 \times 196$ mm

重量 Weight

365 g

AR-6-90



- Heavy-duty die grinder, High Torque
- Maximum air pressure can sustain 150 psi
- Chuck diameters are 3 and 6 mm, support a wide range of abrasive
- 90° angle can grind more object's area

轉速 Speed

22,500 rpm

夾頭 Chuck

$\varnothing 50$ mm

尺寸 Dimensions

$\varnothing 30 \times 55 \times 190$ mm

重量 Weight

358 g

AR-6-45

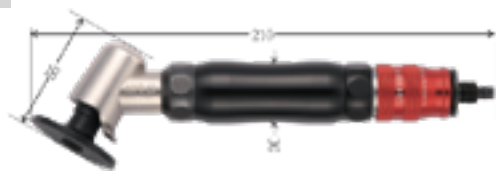

- Heavy-duty die grinder, High Torque
- Maximum air pressure can sustain 150 psi
- Chuck diameters are 3 and 6 mm, support a wide range of abrasive
- Best-seller working angle 45°, Good for handling

轉速 Speed	夾頭 Chuck	尺寸 Dimensions	重量 Weight
22,500 rpm	∅ 50 mm	∅30×55×210 mm	358 g

渦輪式往復研磨機 Turbine Reciprocating Grinder

ATU-07



轉速 Speed	往復行程 Stroke	尺寸 Dimensions	重量 Weight
30,000 rpm	0.3, 0.7, 0.9, 1.2	ø29×208 mm	204 g

- Nylon fiber case, Light weight, Acid resistance, Cold resistance
- Patent reciprocating motor, High-torque, Highly durable
- Working speed is 30,000 rpm maximum, has optional working strokes 0.3, 0.7, 0.9, 1.2 (mm)

AIR-6570



轉速 Speed	往復行程 Stroke	尺寸 Dimensions	重量 Weight
30,000 rpm	0.3, 0.7, 0.9, 1.2	ø29×210 mm	173 g

- Nylon fiber case, Light weight, Acid resistance, Cold resistance
- Slip-proof line in the front-end
- Working speed is 30,000 rpm maximum, has optional working strokes 0.3, 0.7, 0.9, 1.2 (mm)
- High rigidity chuck, diameter 1 & 3 (mm)

AIR-817



轉速 Speed	往復行程 Stroke	尺寸 Dimensions	重量 Weight
32,000 rpm	0.3, 0.7, 0.9, 1.2	ø30×199 mm	217 g

- Nylon fiber case, Light weight, Acid resistance, Cold resistance
- Slip-proof line in the front-end
- Working speed is 30,000 rpm maximum, has optional working strokes 0.3, 0.7, 0.9, 1.2 (mm)
- High rigidity chuck, diameter 1 & 3 (mm)

ARA-600U



轉速 Speed	往復行程 Stroke	尺寸 Dimensions	重量 Weight
30,000 rpm	0.3, 0.7, 0.9, 1.2 mm	ø29×200 mm	230 g

- Slip-proof line in the front-end
- Working speed is 30,000 rpm maximum, has optional working strokes 0.3, 0.7, 0.9, 1.2 (mm)
- High rigidity chuck, diameter 1 & 3 (mm)

葉片式往復研磨機 Air-Saving Reciprocating Grinder



AR-06/03



- T6 Aluminum alloy case, Light weight, High Rigidity
- Reforming Turbine Motor, High efficiency, Low air consumption
- Best-seller air-saving model, fit to all weather and environments

轉速 Speed	往復行程 Stroke	尺寸 Dimensions	重量 Weight
25,000 rpm	0.3, 0.6	ø32×180 mm	196 g

AR-06-A



- Blades are adopted Du-Pout Vespel material, Remarkable low-friction and self-lubricating
- Working stroke can be short at 0.15 (mm)
- Low noise, Low air consumption, Low vibration, High Power and High Torque

轉速 Speed	往復行程 Stroke	尺寸 Dimensions	重量 Weight
28,000 rpm	0.15, 0.3, 0.6	ø32×200 mm	275 g

AIR-8207



- Blades are adopted Du-Pout Vespel material, Remarkable low-friction and self-lubricating
- Working stroke at 0.15, 0.3, 0.7 (mm)
- Low noise, Low air consumption, Low vibration, High Power and High Torque

轉速 Speed	往復行程 Stroke	尺寸 Dimensions	重量 Weight
25,000 rpm	0.15, 0.3, 0.7	ø31×188 mm	219 g

AIR-827



- Nylon fiber case, Light weight, Acid resistance, Cold resistance
- Reforming Turbine Motor, High efficiency, Low air consumption
- Low noise, Low air consumption, Low vibration, High Power and High Torque

轉速 Speed	往復行程 Stroke	尺寸 Dimensions	重量 Weight
28,000 rpm	0.15, 0.3, 0.7	ø32×104 mm	238 g

活塞式往復研磨機 Piston Reciprocating Grinder

ARA-F2000U

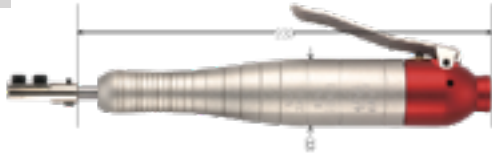

- Multifunctional Grinder, Flat grinding, Precise grinding
- Press-type switch, Easy using, Easy maintenance
- Multiple thread design, Enhancing slip-proof effect

轉速 Speed	往復行程 Stroke	尺寸 Dimensions	重量 Weight
10,000 rpm	2 mm	ø33×220 mm	367 g

TLL-05

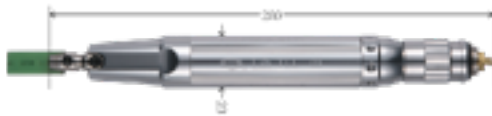

- Working Speed can be 35,000 maximum in Piston model
- Light weight with durable motor
- Working stroke in 0.5 mm, High-torque

轉速 Speed	往復行程 Stroke	尺寸 Dimensions	重量 Weight
35,000 rpm	0.5 mm	ø23×200 mm	210 g

AR-05

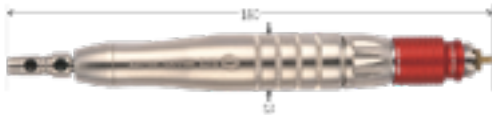

- Working Speed can be 35,000 maximum in Piston model
- Working stroke in 0.5 mm, High-torque
- Highly-precise Production, Adopting High-performance Engineering materials

轉速 Speed	往復行程 Stroke	尺寸 Dimensions	重量 Weight
35,000 rpm	ø 3, 1/8, 2.4 mm	ø23×180 mm	250 g

AIR-597



- High-rigidity motor with Taiwan blades
- Fine working speed but with high-torque
- Suitable for long-strip object

轉速 Speed	左右行程 Stroke	尺寸 Dimensions	重量 Weight
28,000 rpm	2 mm	ø32×210 mm	401 g

AIR-595



- High-rigidity motor with Taiwan blades
- Fine working speed but with high-torque
- 90° bent Grinding Head, Fit to flat grinding
- Highly-durable abrasive steel plate

轉速 Speed	左右行程 Stroke	尺寸 Dimensions	重量 Weight
28,000 rpm	2 mm	ø34×187 mm	573 g

AIR-594



- Wide-range chuck diameter, 1, 3, 6 (mm)
- Good for handling, Delicate paint
- High-Performance motor with long-life usage

轉速 Speed	左右行程 Stroke	尺寸 Dimensions	重量 Weight
28,000 rpm	2 mm	ø32×210 mm	520 g

AIR-A-988



- Patent design with its remarkable motor performance
- High working speed, 35,800 rpm in Swing-track model
- Suitable for long-strip object

轉速 Speed	左右行程 Stroke	尺寸 Dimensions	重量 Weight
35,800 rpm	0.5 mm	ø25×223 mm	325 g

AF-3.0



- High torque sander which can also working up to 13,500 rpm.
- Patent design and precisely assembly, can use air pressure 99.6 maximum.
- 3 different sizes of Stroke can be selected, 3, 1.6, 0.8 mm
- Adjustable air valve, pistol design is good for handle

轉速 Speed	工作行程 Stroke	尺寸 Dimensions	重量 Weight	使用空壓 Air Pressure
13,500 rpm	3.0, 1.6, 0.8 mm	75W×162L mm	885 g	99.6 psi (maximum)

FX-5



- High torque reciprocating grinder which can also working up to 13,500 rpm.
- Patent design and precisely assembly, can use air pressure 99.6 maximum.
- 3 different sizes of Stroke can be selected, 5, 3.2, 1.6 mm
- Adjustable air valve, pistol design is good for handle

轉速 Speed	工作行程 Stroke	尺寸 Dimensions	重量 Weight	使用空壓 Air Pressure
13,500 rpm	5.0, 3.2, 1.6 mm	110W×200L mm	889 g	99.6 psi (maximum)

AR-991



- First generation of our pistol grinder, classic product
- Very easy maintenance
- Adjustable working stroke

轉速 Speed	工作行程 Stroke	尺寸 Dimensions	重量 Weight	使用空壓 Air Pressure
4,500 rpm	0~6 mm	140W×260L mm	657 g	90 psi (maximum)

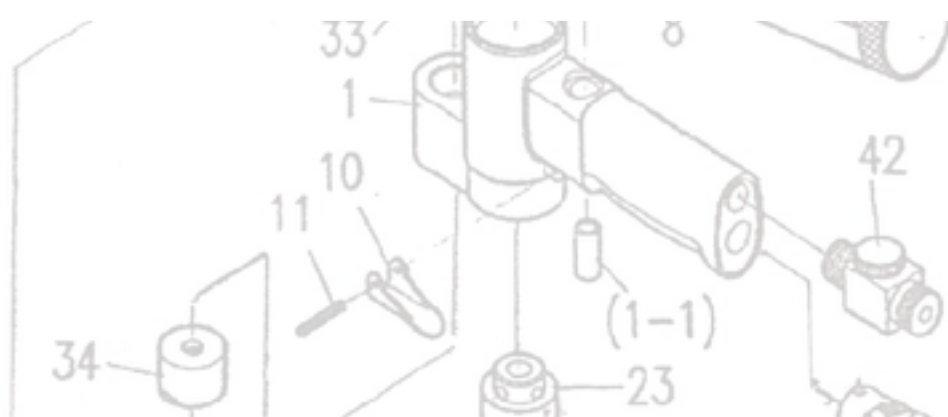
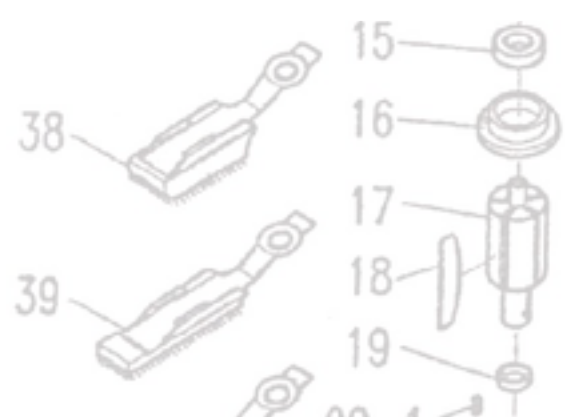

First Generation Series 第一代系列產品

	<p>Reciprocating Grinder TU-03</p>	<ul style="list-style-type: none"> • 往復行程 Working Stroke: 0.3 (mm) • 轉速 Speed: 22,000 (rpm) • 尺寸 Dimensions: $\varnothing 30 \times 220$ (mm) • 重量 Weight: 250 (g)
	<p>Reciprocating Grinder TU-06</p>	<ul style="list-style-type: none"> • 往復行程 Working Stroke: 0.6 (mm) • 轉速 Speed: 22,000 (rpm) • 尺寸 Dimensions: $\varnothing 30 \times 220$ (mm) • 重量 Weight: 250 (g)
	<p>Reciprocating Grinder TU-1.2</p>	<ul style="list-style-type: none"> • 往復行程 Working Stroke: 1.2 (mm) • 轉速 Speed: 22,000 (rpm) • 尺寸 Dimensions: $\varnothing 30 \times 220$ (mm) • 重量 Weight: 250 (g)
	<p>Reciprocating Grinder AR-0.15</p>	<ul style="list-style-type: none"> • 往復行程 Working Stroke: 0.15, 0.3, 0.6 (mm) • 轉速 Speed: 22,000 (rpm) • 尺寸 Dimensions: $\varnothing 28 \times 208$ (mm) • 重量 Weight: 190 (g)
	<p>Swing-Track Grinder AR-993</p>	<ul style="list-style-type: none"> • 左右行程 Working Stroke: 2 (mm) • 轉速 Speed: 8,000 (rpm) • 尺寸 Dimensions: $\varnothing 34 \times 205$ (mm) • 重量 Weight: 460 (g)
	<p>Swing-Track Grinder AR-993N</p>	<ul style="list-style-type: none"> • 往復行程 Working Stroke: 2 (mm) • 轉速 Speed: 8,000 (rpm) • 尺寸 Dimensions: $\varnothing 32 \times 215$ (mm) • 重量 Weight: 362 (g)
	<p>Swing-Track Grinder AR-690</p>	<ul style="list-style-type: none"> • 左右行程 Working Stroke: 2 (mm) • 轉速 Speed: 23,500 (rpm) • 尺寸 Dimensions: $\varnothing 29 \times 189$ (mm) • 重量 Weight: 426 (g)
	<p>Swing-Track Grinder GIA-793</p>	<ul style="list-style-type: none"> • 往復行程 Working Stroke: 2 (mm) • 轉速 Speed: 36,800 (rpm) • 尺寸 Dimensions: $\varnothing 33 \times 179$ (mm) • 重量 Weight: 377 (g)
	<p>Rotary Die Grinder AR-992</p>	<ul style="list-style-type: none"> • 夾頭 Chuck Diameter: $\varnothing 3, 1/8, 2.4$ (mm) • 轉速 Speed: 60,000 (rpm) • 尺寸 Dimensions: $\varnothing 18 \times 135$ (mm) • 重量 Weight: 121 (g)
	<p>Rotary Die Grinder AIR-586</p>	<ul style="list-style-type: none"> • 夾頭 Chuck Diameter: $\varnothing 3, 1/8, 2.4$ (mm) • 轉速 Speed: 65,000 (rpm) • 尺寸 Dimensions: $\varnothing 19 \times 166$ (mm) • 重量 Weight: 125 (g)

First Generation Series 第一代系列產品

	<p>Reciprocating Grinder GT-A70</p>	<ul style="list-style-type: none"> • 往復行程 Working Stroke: 0.6 (mm) • 轉速 Speed: 30,000 (rpm) • 尺寸 Dimensions: $\varnothing 29 \times 220$ (mm) • 重量 Weight: 220 (g)
	<p>Reciprocating Grinder ARA-0.15M</p>	<ul style="list-style-type: none"> • 往復行程 Working Stroke: 0.15, 0.3, 0.7 (mm) • 轉速 Speed: 42,000 (rpm) • 尺寸 Dimensions: $\varnothing 33 \times 220$ (mm) • 重量 Weight: 258 (g)
	<p>Swing-Track Grinder ARA-800U</p>	<ul style="list-style-type: none"> • 往復行程 Working Stroke: 2 (mm) • 轉速 Speed: 36,800 (rpm) • 尺寸 Dimensions: $\varnothing 33 \times 220$ (mm) • 重量 Weight: 336 (g)
	<p>Rotary Die Grinder ARA-380</p>	<ul style="list-style-type: none"> • 夾頭 Chuck Diameter: $\varnothing 3, 1/8, 2.4$ (mm) • 轉速 Speed: 60,000 (rpm) • 尺寸 Dimensions: $\varnothing 18 \times 143$ (mm) • 重量 Weight: 157 (g)
	<p>Bent Die Grinder ARA-A900</p>	<ul style="list-style-type: none"> • 夾頭 Chuck Diameter: $\varnothing 3$ (mm) • 轉速 Speed: 35,000 (rpm) • 尺寸 Dimensions: $\varnothing 19 \times 140$ (mm) • 重量 Weight: 220 (g)
	<p>Bent Die Grinder ARA-A450</p>	<ul style="list-style-type: none"> • 夾頭 Chuck Diameter: $\varnothing 3$ (mm) • 轉速 Speed: 35,000 (rpm) • 尺寸 Dimensions: $\varnothing 19 \times 164$ (mm) • 重量 Weight: 260 (g)
	<p>Flat Grinder (Angle 45°) ARA-450</p>	<ul style="list-style-type: none"> • 砂輪圓徑 Wheel Diameter: $\varnothing 30$ (mm) • 轉速 Speed: 35,000 (rpm) • 尺寸 Dimensions: $\varnothing 19 \times 160$ (mm) • 重量 Weight: 268 (g)
	<p>Flat Grinder (Angle 90°) ARA-900</p>	<ul style="list-style-type: none"> • 砂輪圓徑 Wheel Diameter: $\varnothing 30$ (mm) • 轉速 Speed: 35,000 (rpm) • 尺寸 Dimensions: $\varnothing 19 \times 140$ (mm) • 重量 Weight: 220 (g)
	<p>Rotary Die Grinder AIR-595</p>	<ul style="list-style-type: none"> • 夾頭 Chuck Diameter: $\varnothing 3, 6$ (mm) • 轉速 Speed: 35,000 (rpm) • 尺寸 Dimensions: $\varnothing 32 \times 165$ (mm) • 重量 Weight: 510 (g)
	<p>Bent Die Grinder AIR-596</p>	<ul style="list-style-type: none"> • 夾頭 Chuck Diameter: $\varnothing 3, 6$ (mm) • 轉速 Speed: 28,000 (rpm) • 尺寸 Dimensions: $\varnothing 32 \times 160$ (mm) • 重量 Weight: 502 (g)

First Generation Series 第一代系列產品

	<p>Flat Grinder (Angle 45°) AIR-545</p>	<ul style="list-style-type: none"> • 砂輪圓徑 Abrasive Diameter: \varnothing 50 (mm) • 轉速 Speed: 28,000 (rpm) • 尺寸 Dimensions: \varnothing32×165 (mm) • 重量 Weight: 470 (g)
	<p>Flat Grinder (Angle 90°) AIR-590</p>	<ul style="list-style-type: none"> • 砂輪圓徑 Abrasive Diameter: \varnothing 50 (mm) • 轉速 Speed: 28,000 (rpm) • 尺寸 Dimensions: \varnothing32×155 (mm) • 重量 Weight: 463 (g)
	<p>Rotary Die Grinder AIR-747</p>	<ul style="list-style-type: none"> • 夾頭 Chuck Diameter: \varnothing 3, 6 (mm) • 轉速 Speed: 35,000 (rpm) • 尺寸 Dimensions: \varnothing34×130 (mm) • 重量 Weight: 480 (g)
	<p>Swing-Track Grinder AIR-727</p>	<ul style="list-style-type: none"> • 左右行程 Working Stroke: 2 (mm) • 轉速 Speed: 28,000 (rpm) • 尺寸 Dimensions: \varnothing34×190 (mm) • 重量 Weight: 460 (g)
	<p>Swing-Track Flat Grinder AIR-737</p>	<ul style="list-style-type: none"> • 左右行程 Working Stroke: 2 (mm) • 轉速 Speed: 28,000 (rpm) • 尺寸 Dimensions: \varnothing34×160 (mm) • 重量 Weight: 650 (g)
	<p>Extended Die Grinder AIR-757 (260 mm)</p>	<ul style="list-style-type: none"> • 夾頭 Chuck Diameter: \varnothing 3, 6 (mm) • 轉速 Speed: 35,000 (rpm) • 尺寸 Dimensions: \varnothing34×260 (mm) • 重量 Weight: 670 (g)
	<p>Extended Die Grinder AIR-767 (230 mm)</p>	<ul style="list-style-type: none"> • 夾頭 Chuck Diameter: \varnothing 3, 6 (mm) • 轉速 Speed: 35,000 (rpm) • 尺寸 Dimensions: \varnothing34×230 (mm) • 重量 Weight: 600 (g)

First Generation Series 第一代系列產品

	<p>Rotary Die Grinder MSA-3BSA</p>	<ul style="list-style-type: none"> • 夾頭 Chuck Diameter: $\varnothing 3$ (mm) • 轉速 Speed: 65,000 (rpm) • 尺寸 Dimensions: $\varnothing 17 \times 143$ (mm) • 重量 Weight: 130 (g)
	<p>Bent Die Grinder MAB-121A</p>	<ul style="list-style-type: none"> • 夾頭 Chuck Diameter: $\varnothing 3$ (mm) • 轉速 Speed: 52,500 (rpm) • 尺寸 Dimensions: $\varnothing 17 \times 123$ (mm) • 重量 Weight: 130 (g)
	<p>Bent Die Grinder MAB-122A</p>	<ul style="list-style-type: none"> • 夾頭 Chuck Diameter: $\varnothing 3$ (mm) • 轉速 Speed: 23,500 (rpm) • 尺寸 Dimensions: $\varnothing 17 \times 104$ (mm) • 重量 Weight: 140 (g)
	<p>Flat Grinder (Angle 45°) MAB-123A</p>	<ul style="list-style-type: none"> • 砂輪圓徑 Abrasive Diameter: $\varnothing 30$ (mm) • 轉速 Speed: 23,500 (rpm) • 尺寸 Dimensions: $\varnothing 17 \times 123$ (mm) • 重量 Weight: 175 (g)
	<p>Flat Grinder (Angle 90°) MAB-093A</p>	<ul style="list-style-type: none"> • 砂輪圓徑 Abrasive Diameter: $\varnothing 30$ (mm) • 轉速 Speed: 23,500 (rpm) • 尺寸 Dimensions: $\varnothing 17 \times 118$ (mm) • 重量 Weight: 160 (g)
	<p>Reciprocating Grinder SRT-0.15</p>	<ul style="list-style-type: none"> • 往復行程 Working Stroke: 0.15 (mm) • 轉速 Speed: 55,000 (rpm) • 尺寸 Dimensions: $\varnothing 28 \times 196$ (mm) • 重量 Weight: 166 (g)
	<p>Reciprocating Grinder SRT-03</p>	<ul style="list-style-type: none"> • 往復行程 Working Stroke: 0.3 (mm) • 轉速 Speed: 55,000 (rpm) • 尺寸 Dimensions: $\varnothing 28 \times 196$ (mm) • 重量 Weight: 166 (g)
	<p>Reciprocating Grinder SRT-07</p>	<ul style="list-style-type: none"> • 往復行程 Working Stroke: 0.7 (mm) • 轉速 Speed: 22,000 (rpm) • 尺寸 Dimensions: $\varnothing 28 \times 196$ (mm) • 重量 Weight: 166 (g)
	<p>Reciprocating Grinder SRT-1.2</p>	<ul style="list-style-type: none"> • 往復行程 Working Stroke: 1.2 (mm) • 轉速 Speed: 15,000 (rpm) • 尺寸 Dimensions: $\varnothing 28 \times 196$ (mm) • 重量 Weight: 166 (g)

Abrasive & Accessories 研磨耗材及配件



帶柄砂輪棒 Mounted Points

- Abrasive Diameter: $\varnothing 6$, $\varnothing 8$, $\varnothing 10$ (mm)
- Shank Diameter: $\varnothing 3$ (mm)
- 10 Pcs / Pack



陶瓷帶柄砂輪 Ceramic Mounted Points

- Abrasive Diameter: $\varnothing 6$, $\varnothing 8$, $\varnothing 10$ (mm)
- Shank Diameter: $\varnothing 3$ (mm)
- 10 Pcs / Pack



羊毛磨棒 Felt Bobs

- Abrasive Diameter: $\varnothing 6$, $\varnothing 8$, $\varnothing 10$ (mm)
- Shank Diameter: $\varnothing 3$ (mm)
- 10 Pcs / Pack



碗形小砂輪 Bowl-Shaped Wheels

- Diameter: $\varnothing 30$, Height: 11 (mm)
- Grit: #60, #100, #150
- 10Pcs / Pack



研磨砂布圓片 Abrasive Stickers

- Diameter: $\varnothing 30$ (mm)
- Grit: #100, #150, #240, #320, #400, #600
- 60Pcs / Pack



橡膠研磨輪 Abrasive Rubber Wheels

- Diameter: $\varnothing 20$, $\varnothing 30$, $\varnothing 45$ (mm), Height: 15 (mm)
- 10 Pcs / Pack



機械用鑽石銼刀 Mechanical Diamond Files

- Grit: #150, #200, #300, #400
- 12 Pcs / Pack



鑽石磨棒 Diamond Abrasive Points

- 30 Pcs / pack
- Mix points shape

Abrasive & Accessories 研磨耗材及配件



高鋼性固定夾具 High-Rigidity Set Fixture

- 適用：纖維油石、機械銼刀
- Applicable for Ceramic Abrasive, Mechanical Files



高鋼性固彈性夾具 High-Rigidity Flexible Fixture

- 適用：纖維油石
- Applicable for Ceramic Abrasive



高鋼性研磨鋼片 High-Rigidity Abrasive Plate



Long-Shank Diamond Files

- Grit: #150, #200, #400
- Width: 2.5, 4.0, 6.0, 8.0 (mm)
- Full Length: 180 (mm)
- 12 Pcs / Pack



拋光磨柄 Manual Polishing Tool (For Sticky Abrasive)



鑽石銼刀手把 File Handling

- Chuck Diameter: $\varnothing 3$ & $\varnothing 6$ (mm)



鐵工銼刀 Ironwork Files

- 3 Pcs / Pack



POWER PERFECT CO.LTD.

CONTACT INFO

TEL : +886-2-29854306 **FEX :** +886-2-29868605

WEB : www.lih-taiwan.com.tw

FACEBOOK: @lihtaiwan

Registration No.: 23006630

ADDRESS :

*No. 29, Aly. 16, Ln. 315, Zhongzheng N. Rd.
Sanchong Dist., New Taipei City, Taiwan*

